

## Product Information Motronic IC CJ920

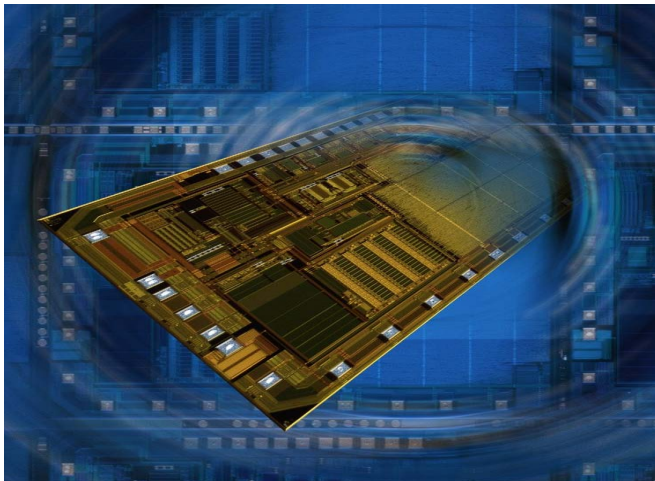

**14 fold power lowside switch with serial fault diagnostic interface**

### Customer benefits:

- ▶ Excellent system know-how
- ▶ Smart concepts for system safety
- ▶ Secured supply
- ▶ Long- term availability of manufacturing processes and products
- ▶ QS9000 and ISO/TS16949 certified

### Features

- ▶ 4 relay drivers (...0.6A)
- ▶ 4 valve drivers (...2.2A)
- ▶ 6 injection valve drivers
- ▶ Package: Power-QFP 64

### General description

#### 14 output stages

- ▶ 6 non inverting 2.2A low side switches
  - ON resistance < 500mW
  - 70V clamping
- ▶ 2 non inverting 2.2A low side switches
  - ON resistance < 500mW
  - 45V clamping
- ▶ 2 non inverting 2.7A low side switches
  - ON resistance < 1W
  - 40V clamping
- ▶ 4 non inverting 0.6A low side switches
  - ON resistance < 500mW
  - 45V clamping
- ▶ 2 outputs of each type, can be connected in parallel all outputs are short circuit protected

#### Serial diagnostic interface

- ▶ Errors detected:
  - short circuit to VBatt (KSUB) (output on)
  - short circuit to ground (KSM) (output off)
  - over temperature (ÜT) (output on)
  - open load (output off) (LA) (no hot open load detection)
- ▶ Individually detected for each output
- ▶ Serial transmission of the output status via a cascable error shift register
- ▶ Register output usable as error signal flag

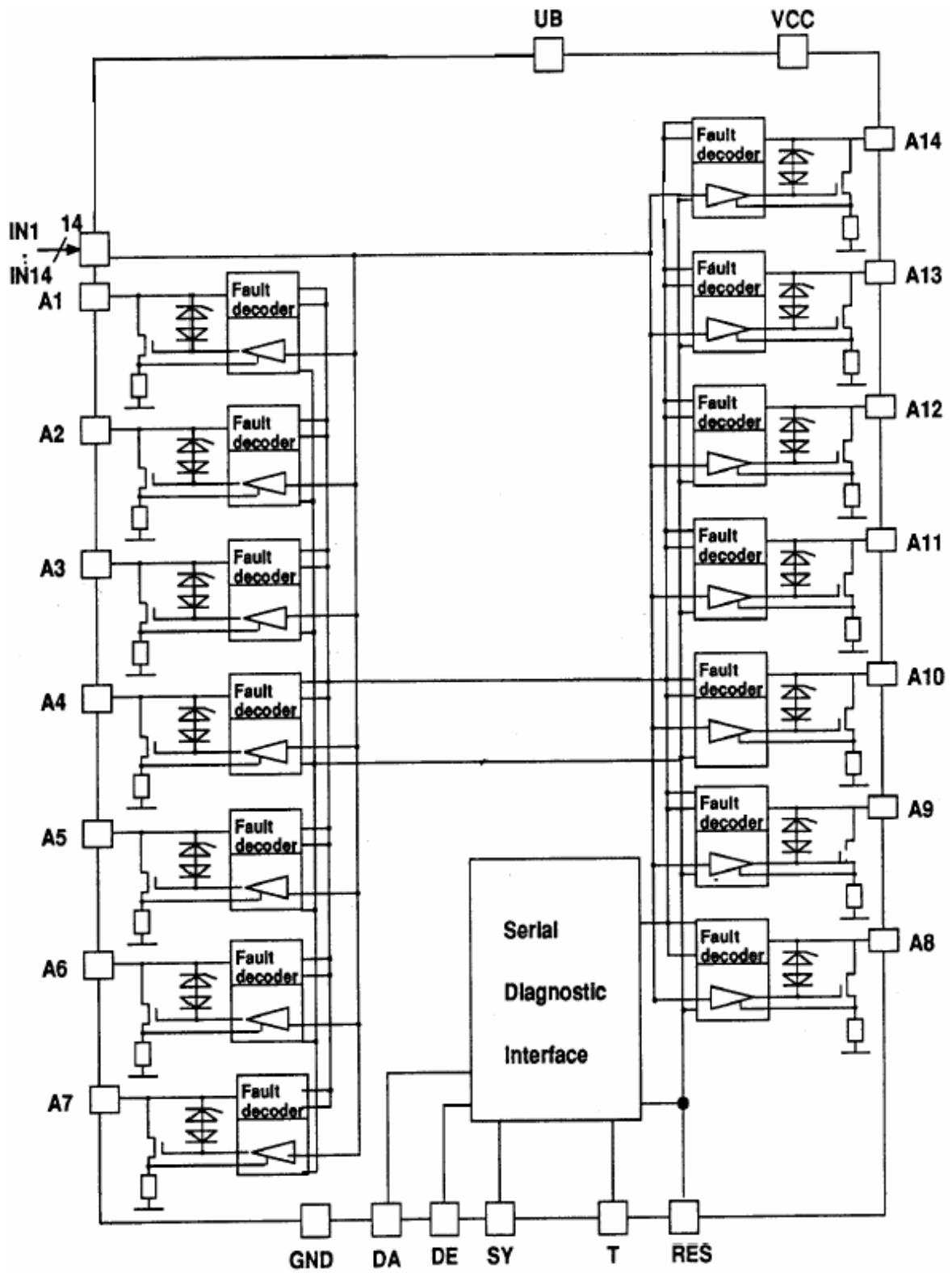



## Functional description

### The device contains 6+2+2+4 DMOS low side switches

- ▶ 6 for up to 2.2A, with  $R_{on} < 0.5W$  and a clamping voltage of 70V
- ▶ 2 for up to 2.2A, with  $R_{on} < 0.5W$  and a clamping voltage of 45V
- ▶ 2 for up to 2.7A, with  $R_{on} < 0.5W$  and a clamping voltage of 45V
- ▶ 4 for up to 2.2A, with  $R_{on} < 1.0W$  and a clamping voltage of 40V

The on resistance values can be reduced to 90% of the nominal value by applying an auxiliary voltage of  $>12V$  at the pin UB. It is possible to connect 2 switches, out of each group, in parallel.

The switches are short circuit protected. In case of overload (overcurrent) they will be turned off after a given filter/delay time. During the delay phase the output current is limited by an internal current control loop. To turn them on again, it is necessary to apply before, either an off signal at the correspondent input pin, or the reset signal.

For supply voltages below 4.4V at pin VCC all outputs are turned off.

### All the low side switches are equipped with fault diagnostic functions

- ▶ Short to battery (KSUB) can be detected at switches which are turned on
- ▶ Short to ground (KSM) can be detected at switches which are turned off
- ▶ Open load (LA) can be detected at switches which are turned off, the device possesses no hot open load detecting function
- ▶ Overtemperature(ÜT) will only be detected at switches which are turned on and encoded in the same bit as the open load signal

If, at one output, several failures occur in a sequence, always the last one will be stored. The failure conditions KSUB, KSM, LA will only be recognized after an integrated filter time. If any failure is recognized, this will be shown by a low signal at the output of the serial interface.

All failure conditions are encoded in two bits per switch and are stored in an internal shift register. This shift register can be read out via a cascable serial diagnostic interface. After each read out cycle this register will be cleared.

The whole status information is encoded in 28 bits. To set the diagnostics information in an 8 bit frame, 4 „high“ bits are added to the status information. So after 32 bits the (optional) input data will be present at the diagnostics output.

## Encoding of the output information

Output 1	BIT 1
	BIT 2
Output 2	BIT 3
	BIT 4
Output 3	BIT 5
	BIT 6
Output 4	BIT 7
	BIT 8
Output 5	BIT 9
	BIT 10
Output 6	BIT 11
	BIT 12
Output 7	BIT 13
	BIT 14
Output 8	BIT 15
	BIT 16
Output 9	BIT 17
	BIT 18
Output 10	BIT 19
	BIT 20
Output 11	BIT 21
	BIT 22
Output 12	BIT 23
	BIT 24
Output 13	BIT 25
	BIT 26
Output 14	BIT 27
	BIT 28
Don't care	BIT 29
	BIT 30
Don't care	BIT 31
	BIT 32
DE	BIT n

### Output 13

H	H	o.k.
L	H	LA/ÜT (open load/ over temperature)
H	L	KSUB (i.e. short to battery)
L	L	KSM (i.e. short to ground)

## PIN configuration

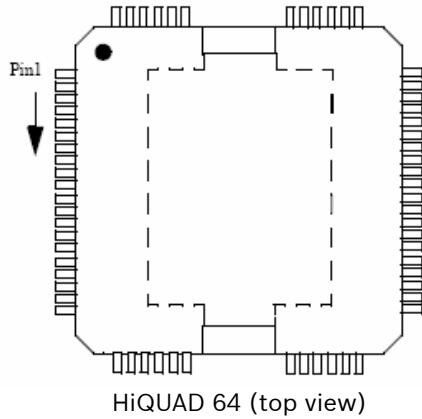

Pin	Name	Function
16	A11	Output 11
15	A12	Output 12
37	A13	Output 13
38	A14	Output 14
57	RES	Reset
60	VCC	Supply voltage $V_{CC}$
62	UB	Auxiliary supply $U_B$
26+27 +58+59	GND 1..4	Ground
56	DE	Diag. data in
61	DA	Diag. data out
55	SY	Diag. synchronization
54	T	Diag. clock

## PIN description and pinout

E1...E14: Signal inputs (with internal pull up) for the low side switches, a low signal will turn on the corresponding switch

A1...A14: Low side switch outputs, if more than 1 pin is assigned to an output, these pins have to be connected in parallel

VCC: Supply voltage (typ. 5V)

UB: Auxiliary supply voltage (typ 14V) to reduce  $R_{on}$

GND1..4: Ground pins, all of them have to be connected in parallel

RES: Reset input, active low, turns off all switches and clears the error shift register

Diagnostic interface DE, DA, T, SY:

DE: Data input, with an internal pull up, to daisy chain the interface with other devices (e.g. CJ920 or one out of the CJ4xx family)

DA: Diagnostics data output (open drain), gives a low signal if an error at any output channel within the device or in the chain is detected

SY: A low level, applied to this input, freezes the status of the error shift register, the register now can be read out via the serial output DA by applying the clock signal

T: Clock signal, each rising edge shifts the next bit to the output DA (and reads in the next bit at the input DE)

## Pin Description

Pin	Name	Function
45	E1	Input 1
43	E2	Input 2
42	E3	Input 3
8	E4	Input 4
11	E5	Input 5
10	E6	Input 6
9	E7	Input 7
12	E8	Input 8
44	E9	Input 9
41	E10	Input 10
13	E11	Input 11
14	E12	Input 12
40	E13	Input 13
39	E14	Input 14
46+47	A1	Output 1
50+51	A2	Output 2
33+34	A3	Output 3
6+7	A4	Output 4
19+20	A5	Output 5
2+3	A6	Output 6
4+5	A7	Output 7
17+18	A8	Output 8
48+49	A9	Output 9
35+36	A10	Output 10

## Contact

**Robert Bosch GmbH**  
Sales Semiconductors  
Postbox 13 42  
72703 Reutlingen  
Germany  
Tel.: +49 7121 35-2979  
Fax: +49 7121 35-2170

**Robert Bosch Corporation**  
Component Sales  
38000 Hills Tech Drive  
Farmington Hills, MI 48331  
USA  
Tel.: +1 248 876-7441  
Fax: +1 248 848-2818

**Robert Bosch K.K.**  
Component Sales  
9-1, Ushikubo 3-chome  
Tsuzuki-ku, Yokohama 224  
Japan  
Tel.: +81 45 9 12-83 01  
Fax: +81 45 9 12-95 73

E-Mail: [bosch.semiconductors@de.bosch.com](mailto:bosch.semiconductors@de.bosch.com)

Internet: [www.bosch-semiconductors.de](http://www.bosch-semiconductors.de)

© 02/2006 All rights reserved by Robert Bosch GmbH including the right to file industrial property rights

Robert Bosch GmbH retains the sole powers of distribution, such as reproduction, copying and distribution.

For any use of products outside the released application, specified environments or installation conditions no warranty shall apply and Bosch shall not be liable for such products or any damage caused by such products.